

2013-08

# Design of ECG Sensor Interface for Biosignal Extraction

Mazima, Johevajile

International Journal of Innovative Technology and Exploring Engineering (IJITEE)

---

<http://dspace.nm-aist.ac.tz/handle/123456789/428>

*Provided with love from The Nelson Mandela African Institution of Science and Technology*

# Design of ECG Sensor Interface for Biosignal Extraction

Johevajile Mazima, Michael Kisangiri, Dina Machuve

**Abstract** – The main objective of this paper is to propose the design of a sensor interface for gathering biosignal. This signal is acquired from the patient's body by the ECG sensor. The interface includes the instrumentation amplifier, bandpass filter, notch filter and the gain amplifier for improving the weak signal captured from the human body. The interface designed is intended to be used in supporting remote monitoring devices for the patients living in areas with limited access to medical assistance or scarce clinical resources especially in rural areas. The patient monitoring systems are expected to use the GSM/GPRS network directly through GSM/GPRS modem instead of using additional devices like Personal Digital Assistant (PDA). Since, the network is currently available in remote area for access. The design is helpful to improve people's quality of life, as well as to allow an improvement in the government attendance indices.

**Index Terms:** Band Pass Filter, Biosignal, Electrocardiography, ECG Sensor, Notch Filter

## I. INTRODUCTION

Electrocardiography (ECG) is the interpretation of the electrical activities of the heart over a period of time. The biosignal are extracted right from the body by the electrodes placed on different locations. The signal measured and monitored a biological being is commonly used to refer to an electrical signal called biosignal. Bio electrical signals (biosignal) are the electrical currents generating the electrical potential difference across a tissue, organs or cell system called nervous system[1-3].

In the heart muscle cell, electric activation takes place by means of the same mechanism as in the nerve cell from the inflow of Na ions across the cell membrane. The amplitude of the action potential is also similar, being 100 mV for both nerve and muscle. The duration of the cardiac impulse is, however, two orders of magnitude longer than in either nerve cell or skeletal muscle cell. As in the nerve cell, repolarization is a consequence of the outflow of K ions. The duration of the action impulse is about 300 ms V[4-6].

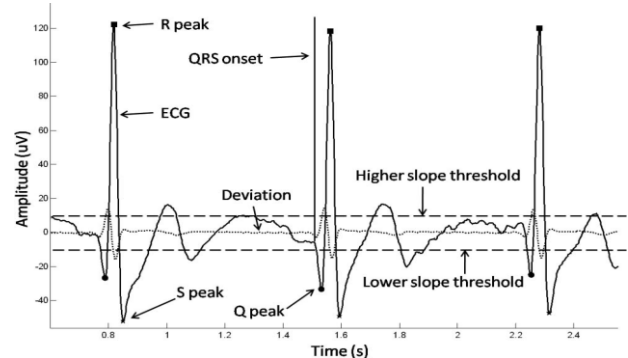

Fig. 1 Normal ECG waves [7]

Normal values for amplitude and duration of ECG parameters are usually as:

Amplitude: P wave 0.25mV, R wave 1.60mV, Q wave 25% of R wave and T wave 0.1mV to 0.5mV as shown in Fig. 1  
Duration: P-R interval 0.12 to 0.20sec, Q-T interval 0.35 to 0.44 sec, P wave interval 0.11 sec and QRS interval 0.10 sec [8-10].

The ECG signal is always very weak that needs a boost. Biosensors also develop very low output signals. Modern analog circuits systems consist of basic integrated operational amplifiers, which are built easily up to amplify or buffer signals. A modified morphological filtering (MMF) technique is used for signal conditioning to achieve baseline correction and noise suppression with minimum signal [11, 12].

## II. DESIGN CONSIDERATIONS

The selection and placement of the electrodes have been considered for the single channel ECG system. These are electrodes which can measure the weak signal less than 8mV. The typical electrocardiogram (ECG) signal has voltage of 0.05 to 5mV.

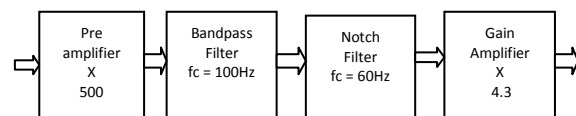

Fig. 2 ECG Conditioning Block Diagram

The ECG signal is detected by ECG probe that converts it into an electrical signal which is pre amplified at the first stage. The signals that are captured from the electrodes have some amount of noise. It needs the proper signal analysis to remove these errors and noise. Hence, the second stage consists of the bandpass filter and notch pass filter [13] as in Fig. 4 which is designed to suppress the unwanted signal (noise) The third stage has the gain amplifier which sets the appropriate level of signal to be read by the analog to digital convertor (ADC) and microcontroller [14, 15].

**Manuscript received on August, 2013.**

**Johevajile KN Mazima**, Department of Computational and Communication Science and Engineering, Nelson Mandela African Institute of Science and Technology, Arusha, Tanzania.

**Dr. Michael Kisangiri**, Department of Computational and Communication Science and Engineering, Nelson Mandela African Institute of Science and Technology, Arusha, Tanzania.

**Dina Machuve**, Department of Computational and Communication Science and Engineering, Nelson Mandela African Institute of Science and Technology, Arusha, Tanzania.

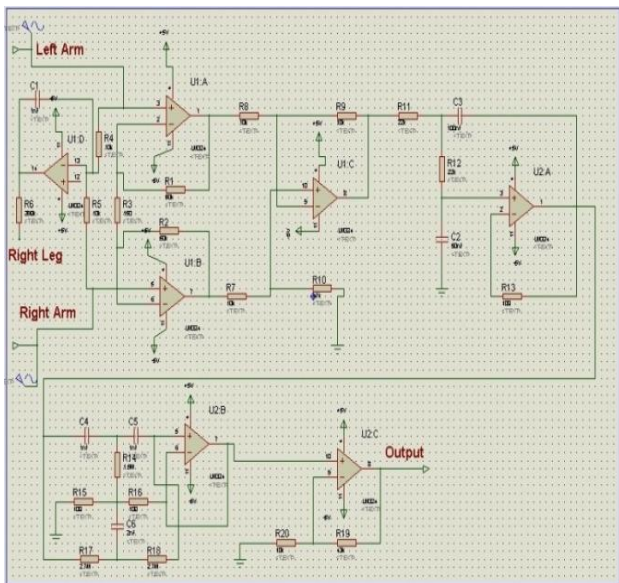

Fig. 3 ECG Sensor Interface Schematic

**A. Pre Amplification**

LM324 op amp[16] is selected in this work, because it is a bipolar metal oxide semiconductor (BiMOS) op amp [17]. BiMOS technology has the circuit design that uses both bipolar junction transistor (BJT) and metal oxide semiconductor field effect transistor (MOSFET)[18-20]. Hence LM324 op amp does not allow the leakage of currents that may affect the signal as in BJT op amp (741). It produces real ideal response for biometric signals.

The differential amplifiers are used to create instrumentation amplifier. This is done by using basic three op amps. This is made up of two parts, the differential amplifier and the gain stage [21]. These two parts are set to total gain (G1) as shown below.

$$G1 = \frac{2R + R3}{R3} \left( \frac{R9}{R8} \right) = 668$$

$$R1 = R2 = R$$

**A. Band Pass Filter**

The signal from the instrumentation amplifier is filtered by the bandpass filter for the bandwidth of 1 to 102 Hz [22]. The transfer function of the bandpass filter is

$$fc = \frac{1}{2\pi\sqrt{R11C2R12C3}} = 102 \text{ Hz}$$

fc = cut off frequency

**B. Notch Filter**

Proper protecting and safety consideration are considered to ease the external noise such electromagnetic interference, it is preferred to get rid of this type of noise in the preprocessing stage. The notch (band stop) filtering with cut off frequency  $fc = 60 \text{ Hz}$  is designed to suppress such noise [23] and as shown in Fig. 5.

$$fc = \frac{1}{2\pi RC} = 60 \text{ Hz}$$

$$R17 = R18 = R, C4 = C5 = C$$

**C. Right leg drive**

Right Leg Drive is designed to remove the common mode noise produced from the body. The two signals to the instrumentation amplifier from the leads positioned on the right and left arm are added up, inverted and amplified back into the body through the right leg by a common-mode amplifier. Since the patient is frequently not grounded; the right leg electrode is connected to the output of a supplementary op amp.

The common mode voltage on the body is sensed by two averaging resistors R4 and R5, inverted and fed back to the right leg through R6. This circuit drives a very little amount of current into the right leg to equal the displacement currents flowing in the body. The body hence becomes a summing junction in a feedback loop and the negative feedback from this circuit drives the common mode voltage to a low value.

The circuit also protects the patient, if an abnormally high voltage should appear between the patient and ground due to electrical leakage or other means, the supplementary op amp in the right leg circuit saturates. The resistance R6 between the patient and ground has enough power for the protection in case the supplementary op amp saturates shown in Fig. 3. Common mode output (V) = (V2+V1)/2

**D. Gain Amplifier**

The amplification stage as shown in **Error! Reference source not found.** has the only purpose to boost the amplitude of the bioelectric signal up to be understood by the microcontroller (to 4.7V) [24, 25].

$$\text{The amplifier gain is } G2 = \frac{R19}{R20} = 4.3$$

$$\text{The overall system gain (G) = } G1 \times G2 \\ G = 2870$$

**E. Power Supply**

The system components are set use +5V at their positive terminals and -5V at their negative terminals, and reference voltage set to ground.

III. RESULTS

When designing the ECG signal conditioning circuit, each stage has been tested by simulation using proteus. Testing has been performed using a sinusoidal wave, since the ECG software generator in proteus for ECG signal generation was not easily available. The power supplies used are +5 V and -5 V dc for the positive and negative terminals respectively. The input has been set to 1 to 5mV offset voltages.

The test results are:

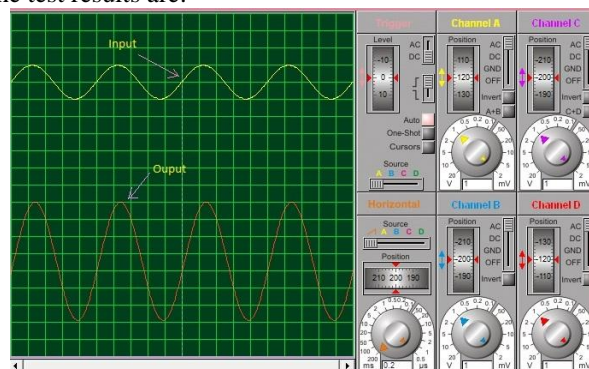

Fig. 4 Input and Output of ECG Signal Conditioning Circuit



Fig. 5 Notch Filter Frequency Response

From the tests, it is verified that each block functions correctly. The output resulted is sufficient for the ADC analysis which suits at the microcontroller level. The output at the notch filter end has successfully suppressed the electromagnetic noise at 60Hz.

#### IV. CONCLUSION

A sensor interface has been designed for continuously capturing the physiological signals of a patient. It has the voltage output level required to suit to the microcontroller. This technology has the potential for offering a wide range of benefits to patients, medical society and whole the community at large especially in rural areas in Tanzania. There are many advantages of this technology at home or in hospitals to replace the face to face communication between a patient and a physician. The physiological signal can be measured from the patients, and then sent to the hospital remotely automatically when connected to the microcontroller without the need of them going to hospital in person. In addition, the medical personnel can take care of a few patients simultaneously, and thus, the personnel expenses can be reduced.

#### REFERENCES

- [1] NeuroSky, "BrainWaveSignal(EEG)of NeuroSky," 15 December, 2009.
- [2] S. Carmel and A. J. Macy, "Physiological signal processing laboratory for biomedical engineering education," in *Engineering in Medicine and Biology Society, 2005. IEEE-EMBS 2005. 27th Annual International Conference of the*, 2006, pp. 859-862.
- [3] P. Kligfield, *et al.*, "Recommendations for the Standardization and Interpretation of the Electrocardiogram," *Journal of the American College of Cardiology*, vol. 49,2007, pp. 1109-1127.
- [4] J. T. Tikkanen, *et al.*, "Long-term outcome associated with early repolarization on electrocardiography," *New England Journal of Medicine*, vol. 361,2009, pp. 2529-2537.
- [5] G. Wagner, *Marriot's practical electrocardiography 10 Ed*: Wolters Kluwer Health, 2001.
- [6] B. Surawicz and T. Knilans, *Chou's electrocardiography in clinical practice: adult and pediatric*: Saunders, 2008.
- [7] C.-T. Lin, *et al.*, "An intelligent telecardiology system using a wearable and wireless ECG to detect atrial fibrillation," *Information Technology in Biomedicine, IEEE Transactions on*, vol. 14,2010, pp. 726-733.
- [8] M. Joshi,S Patel and Dr. L Hmurcik, "Improvements in Electrocardiography Smoothing and Amplification." University of Bridgeport,2008
- [9] K. Joshi, "Early Myocardial Infarction Detection," San Jose State University, 2009.
- [10] D. Parekh, "Designing Heart Rate, Blood Pressure and Body Temperature Sensors for Mobile On-Call System," 2010.
- [11] Y. Sun,K L Chan and S M Krishnan., "ECG signal conditioning by morphological filtering," *Computers in biology and medicine*, vol. 32,2002, pp. 465-479.
- [12] C. Park, *et al.*, "An ultra-wearable, wireless, low power ECG monitoring system," in *Biomedical Circuits and Systems Conference, 2006. BioCAS 2006. IEEE*, 2006, pp. 241-244.
- [13] M. J. Lee, "Signal Conditioning Circuit Design," M. S. University, Ed., ed: Capstone Design Team 5, November 2011.
- [14] M. Ekström, "Small wireless ECG with Bluetooth™ communication to a PDA," *Mälardalen University, Thesis,(Msc)*, 2006.
- [15] N. R. Reza Fazel-Rezai, Ahmed Rabbi, and D. L. a. W. Ahmad, "Biomedical Signal Transceivers," U. O. N. Dakota and USA, Eds., ed: InTech, August, 2011, pp. 486.
- [16] T. Jian-jun, "A High Performance and Low-cost Instrumental Amplifier Based on LM324 [J]," *Telecommunication Engineering*, vol. 3,2004, pp. 038.
- [17] K. L. McLaughlin, "BIMOS logic gate," ed: Google Patents, 1987.
- [18] P. Galy, *et al.*, "BIMOS transistor and its applications in ESD protection in advanced CMOS technology," in *IC Design & Technology (ICIDT), 2012 IEEE International Conference on*, 2012, pp. 1-4.
- [19] M. Tsai, "Bipolar junction transistor," ed: Google Patents, 2008.
- [20] S.-h. Fan, *et al.*, "BIPOlar JUNCTION TRANSISTOR," ed: US Patent 20,120,319,243, 2012.

- [21] M. Shojaei-Baghini, *et al.*, "A low-power and compact analog CMOS processing chip for portable ECG recorders," in *Asian Solid-State Circuits Conference*, 2005, pp. 473-476.
- [22] R. Fazel-Rezai, *et al.*, "Biomedical Signal Transceivers."
- [23] C.-M. Chang, *et al.*, "Voltage-mode notch, lowpass and bandpass filter using current-feedback amplifiers," *Electronics Letters*, vol. 30,1994, pp. 2022-2023.
- [24] H. W. Bode, *Network analysis and feedback amplifier design*: Van Nostrand Reinhold, 1956.
- [25] E. M. Spinelli, *et al.*, "AC-coupled front-end for biopotential measurements," *Biomedical Engineering, IEEE Transactions on*, vol. 50,2003, pp. 391-395.



Johevajile K.N Mazima is currently a master's student in Information and Communication Science and Engineering at NM-AIST majoring in Communication Science and Engineering. He received BE (Hons) degree in Electronics and Communication Engineering from St Joseph University In Tanzania (SJUIT) in November 2009. He also received Full Technician Certificate (FTC) in Mechanical Engineering from Arusha Technical College in Tanzania in November 1997. He worked with Kashasha Village Technology Training Center (VTTC) as the Mechanical Instructor in March 1998, then as Academic Coordinator. He also worked with JohaTrust as an IT manager in 2010.

His interest includes Electronics, Network Design, Biomedical Engineering, Data communication, Data Transmission and Wireless Telecommunications. He is a member of the institution of Engineers Tanzania. He is registered as Graduate Engineer (Electronics and Communication) with the Engineers Registration Board (ERB) of Tanzania.



Dr. Kisangiri Michael received his PhD (Telecommunication Engineering) from Wroclaw University of Technology Poland, Institute of Telecommunication and Acoustics in December 2008. In April 2002 he graduated from the same University, Master of Science in Telecommunication Engineering (Department of Radio communication) with specialization in Mobile Communication. He has been working with Dar es Salaam Institute of Technology (D.I.T) in the department of Electronics and Telecommunication Engineering since October 2002 as Assistant Lecturer to November 2008, then as a Lecturer to November 2011. In December 2011, He joined Nelson Mandela African Institute of Science and Technology (NM-AIST) in the College of Computational and Communication Science and Engineering (CoCSE) as a Lecturer. His area of interests includes evolutionary computation in Telecommunication networks; Antenna design and Triangular mesh modeling.

#### Projects

1. Electromagnetic optimizations in wireless networks
2. Direct Matrix Manipulation (DMM) methodologies as a Speeding up catalyst
3. Call planning and optimization for GSM networks
4. Designing of mesh wireless networks
5. Spread Spectrum System for measuring distance of moving plane from the radar
6. Planar Inverted F antenna (PIFA) design for GSM 900/1800
7. Emission of mobile phone radiation into operator's head
8. Propagation and Traffic analysis in GSM Networks



Dina Zawadi Machuve is currently a PhD student in Information and Communication Science and Engineering at NM-AIST majoring in Information Technology Development and Management. She received BSc (Hons) degree in Electrical Engineering from the University of Dar es Salaam in 2001. She received MS degree in Electrical Engineering from Tennessee Technological University, USA in 2008. She joined Nelson Mandela -AIST in April, 2012 as Assistant Lecturer in the College of Computational and Communication Science and Engineering (CoCSE) Her interests include Data Communication, Telecommunication Network Design and Database Management Systems. She is a member of IEEE. She is registered as Professional Engineer (Electrical) with the Engineers Registration Board (ERB) of Tanzania.